

Automatic greasing systems for excavation and mobile equipment

- Wasting man hours every day lubricating your excavation equipment?
- Want to ensure that your equipment is reliably, thoroughly greased?
- Want to reduce expensive repair bills caused by dry bearings and components?
- Want to reduce your maintenance costs by cutting grease wastage?

Major has a solution for you. Our range of automatic greasing systems will automatically grease vital points in your equipment at regular intervals, with a pre-determined amount of grease. Our systems incorporate a programmable automatic grease pump.



- ✓ Grease up to 300 points automatically
- ✓ Output pressure up to 250 bar
- ✓ Tough and durable, die cast aluminium chassis with polycarbonate reservoir
- ✓ Pumps up to NLGI grade 2 viscosity grease
- ✓ Reservoir can be fitted with 4 separate pumps
- ✓ IP56 rated casing means it can be mounted in many locations

Specifications of TP1 Pump

- ✓ Max. working pressure: 300Bar (limited by integral relief valve)
- ✓ Delivery: 3cc/minute/pump
- ✓ Operating temp.: -30 to +80 degrees C
- ✓ Grease capacity: 2.4, 3.5, 5 or 7 kgs
- ✓ Supply voltage: 12 or 24VDC
- ✓ 100 mesh filter on grease top up nipple

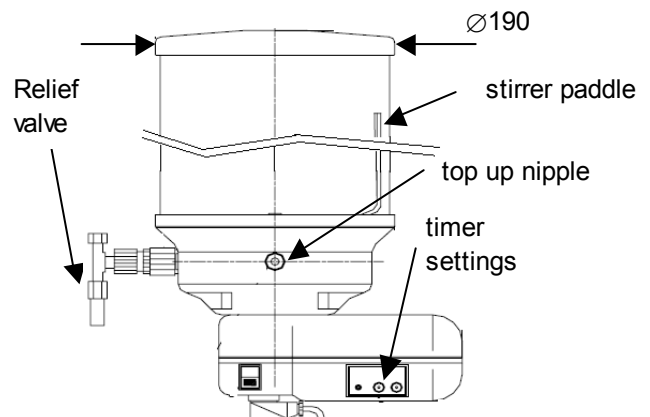

Distributor valving

To complete the automatic, centralised greasing system requires a network of distributor valving. The TLS progressive distributors are compact and flexible. They are available in a variety of displacements for different lubricant dosing. Monitoring options such as burst disc overpressure valves, pressure gauges, relief valves and cycle counter switches can be fitted. Optional manual grease nipples at the valve can be used to assist with fault diagnosis.



Specifications— Distributor valves

- ✓ Max. working pressure: 300Bar
- ✓ Displacements: 0.045, 0.075, 0.11 and 0.165 cc
- ✓ Steel body with tempered steel pistons
- ✓ Cycle counter option
- ✓ Inlet grease nipple option
- ✓ Burst disc overpressure valve option

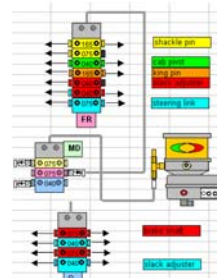

Talk to our sales engineers for detailed information and pricing of a complete TLS automated, centralised greasing system

Major

Major Sales and Service has a large range of equipment and services

- HYDRAULICS
- PNEUMATICS
- LUBRICATION
- COMBUSTION
- REFRACTORY
- SYSTEM DESIGN
- INSTALLATION
- COMMISSIONING
- 24 HOUR SERVICE
- SPARE PARTS



Automatic, centralised greasing systems for plant and equipment

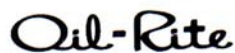

Chain lubrication, brush oilers, level gauges, sight ports, spray valves



Small lubrication systems



Centralised lubrication systems



Grease distributor valves and cartridge greasing units



Hydraulic, pneumatic, cylinders, filters, pumps and motors



Hose and Fittings



Hydraulic and pneumatic seals and packings



Filters, tank accessories, valves and accumulators



Special service valves, high/low temp., self monitoring, safety approved



Specialty Burners and Combustion Equipment



Design, supply, installation and maintenance

Major Sales and Service

(a division of Major Furnace Australia Pty Ltd; ABN: 25 116 352 759)

100 Fairbank Road, Clayton
Victoria, 3169

Phone: (03) 9558 2433
Fax: (03) 9558 2466
Email: major@majoreng.com.au
Web: www.majoreng.com.au